

## ExTensor

Electric actuators for potentially explosive atmospheres

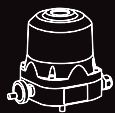

**Ex actuators**

Product catalogue

[stellantriebe.de](http://stellantriebe.de)



ARIS Stellantriebe GmbH  
Rotter Viehtrift 9  
D-53842 Troisdorf

T. +49 2241 25186 - 0  
F. +49 2241 25186 - 99  
aris@stellantriebe.de

stellantriebe.de

# TABLE OF CONTENTS

## **ExTensor – the actuator**

General description and benefits	04
Benefits at a glance	06
Future-proof technology	08
Applications	10
Technical data	12



### **Size S**

ExTensor	14
----------	----



### **Size M/L**

ExTensor	16
----------	----



### **Size XL**

ExTensor	18
----------	----

## **ExTensor options**

Mechanical	20
Functional enhancements, electronic	21

## **Explanations regarding approval / Ignition protection type**

ExTensor Zone 1 / Zone 2 (gas)	22
ExTensor Zone 21 / Zone 22 (dust)	23

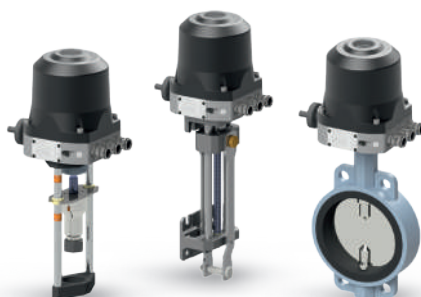

## **ExTensor – variants**

ExTensor Linearis	24
ExTensor Ventaris	25
ExTensor complete units	26

## ExTensor

# Electric actuators for potentially explosive atmospheres

The new actuator series **ExTensor from ARIS Stellantriebe GmbH** is based on the well-known and proven benefits of the Tensor2 series.

- > This is a high-precision, multi-turn, electronically controlled actuator with contactless, wear-free position detection.
- > Typical applications are the adjustment of butterfly, ball, control and other valves, linear control units and dosing pumps.
- > The actuators are used as rotary and part-turn actuators.
- > All parameters of the actuator are fully electronically configurable.
- > The intuitive menu navigation is conveniently shown on an OLED display.

The mechanical power transmission takes place via a low-backlash metal gear unit, which is driven



The new ARIS ExTensor actuator series is approved for operation in potentially explosive atmospheres, in accordance with ATEX Directive 2014-34-EU, and conforms to IECEx.

The following designations in accordance with Directive 2014-34-EU have been achieved.

### **Atex (gas)**

CE (0637) Ex II 2 G Ex db IIC T6 Gb  
Temperatures -20 °C to +60 °C

### **Atex (dust)**

CE (0637) Ex II 2 D Ex tb IIIC  
T 80 °C Db

by a fully controllable BLDC motor. It goes without saying that these are extremely smooth-running and wear-resistant.

The gear unit is maintenance-free with life-long lubrication.

Due to externally mounted gear extensions (substructure gear stages, spur gear stages and planetary stages), a power extension of up to 500 Nm is possible (secondary version).

The basic actuator (without external enhancement levels) delivers a nominal torque of 40 Nm (primary version).

Actuating times from 1 s/90° to 500 s/90°.  
- flexibly configurable, depending on the torque range.

### **IP protection rating**

IP66 and IP67

In accordance with DIN EN 60529

### **EU type-examination certificate no.:**

IBExU22ATEX1066 X

Type of construction: Flameproof enclosure (gas), protection by housing (dust)

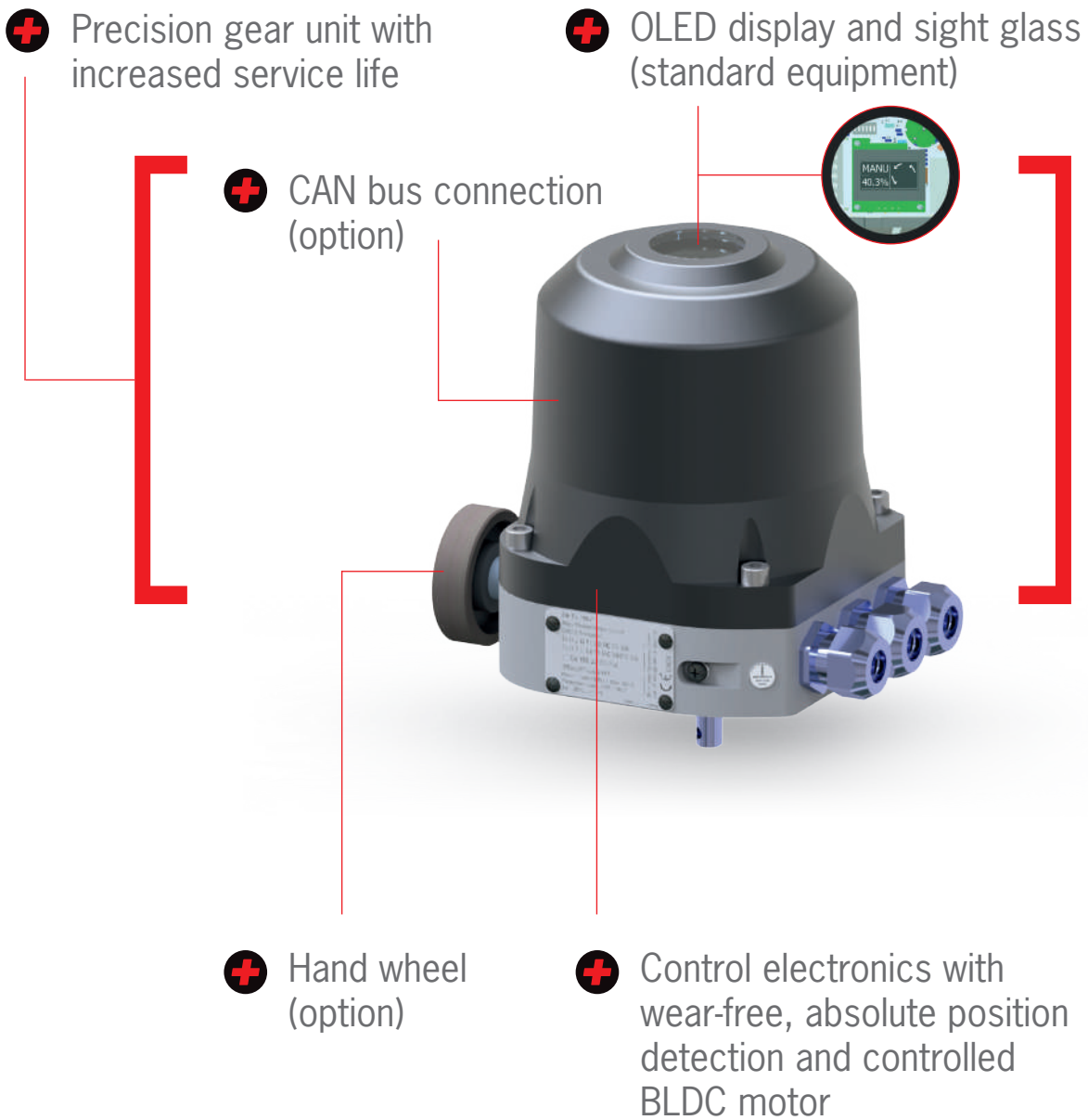

**PLEASE NOTE**

Despite careful checking of all data provided in the catalogue, we accept no liability for any incorrect or incomplete information. We reserve the right to make technical changes. No part of this document may be reproduced or transmitted in any form or by any means, electronic or mechanical, including photocopying, recording or otherwise, without prior written permission. Illustrations may differ from the actual scope of delivery. Illustrations may contain additional options.

# ExTensor

## All the benefits at a glance

### Properties (mechanical)

- > Robust, smooth-running and wear-optimised metal gear unit for maximum precision and service life
- > Aluminium housing – lower part milled, anodised; upper part (cover) gravity die-cast, powder-coated
- > Sight glass / position indicator – standard equipment
- > Manual operation via hand wheel, currentless (option)
- > Particularly compact dimensions, high power density
- > Torques up to 500 Nm
- > Long service life (up to 259 times longer than DIN EN 15714-2:2010-02)
- > Cable entries, thread M25x1.5
- > Terminals up to 4 mm<sup>2</sup> conductor cross-section (option)
- > Additional mechanical potentiometer (option)
- > Various output shaft shapes – also customised
- > Mounting flanges in accordance with ISO5211 – Additional industry standard 50 x 65 mm

### Properties (electrical)

- > Flexibly adjustable, electronically programmable travel from 10° to 100 revolutions
- > Position detection accurate to 0.03°
- > Multi-voltage power supply 85 - 265 V AC, alternatively 24 V DC
- > Torque and actuating time can be adjusted by the customer
- > Electronically controlled torques and actuating times
- > Blocking system and overload protection, programmable start-up and control ramps, special characteristic curves, etc.
- > Up to 4 auxiliary switches (bistable relays)
- > Optimised menu guidance, simplified navigation, faster start-up
- > Multi-line OLED display with position indicator
- > Functionality can be expanded based on requirements (positioner I-ACT, current output, potentiometer, (CAN bus) via software activation code. No exchange of hardware required - Immediate availability – no lengthy delivery times.
- > Intelligent Torque Control System i-TC with torque shut-off and confirmation
- > CAN bus module (option)
- > Up to 100 % duty cycle (ED)

## Electrical data

- > AC supply voltage: 85...265 V AC (50/60Hz)
- > DC supply voltage: 24 V DC ( $\pm 10\%$ )
- > Maximum power consumption 60 V A



## Standards and guidelines

These electric actuators for potentially explosive atmospheres comply with the Safety and Health Directive 2014/34/EU by conforming to EN IEC 60079-0:2018 / IEC 60079-0:2017 Edition 7.0 and EN 60079-1:2014 / IEC 60079-1:2014 Edition 7.0 and IEC 60079-31:2014.

The following EC directives also apply: EMC Directive 2014/108/EC DIN EN 61000-3-2, DIN EN 61000-3-3, DIN EN 61000-6-2, DIN EN 61000-6-3, DIN EN 61000-6-4, DIN EN 55011.

Harmonised standards applied: MaschRI 2006/42/EC DIN EN 61010-1:2011-0. DIN EN 12100:2011-03. Protection rating by enclosures (IP code) Protection rating test DIN EN 60529 (IP66/IP67).

### The product also complies with the essential requirements of the following EU directives:

EMC Directive 2014/30/EU (DIRECTIVE 2014/30/EU OF THE EUROPEAN PARLIAMENT AND OF THE COUNCIL of 26 February 2014)

Low Voltage Directive 2014/35/EU (DIRECTIVE 2014/35/EU OF THE EUROPEAN PARLIAMENT AND OF THE COUNCIL of 26 February. RoHS Directive 2011/65/EU + 2015/863/EU (DIRECTIVE 2011/65/EU OF THE EUROPEAN PARLIAMENT AND OF THE COUNCIL of 8 July)

### Conformity with the following harmonised standards has been ensured:

- > EN ISO 12100:2011-03 ("Safety of machinery")
- > DIN EN 61010-1:2011-07 ("Safety requirements for electrical equipment for measurement, control and laboratory use")
- > DIN EN 61000-6-2:2005 ("EMC, Immunity in industrial environments")
- > DIN EN6100-6-3:2007 + A1:2011 ("EMC, Emission in business and commercial environments")

The product is declared as partly completed machinery in accordance with EC Directive 2006/42/EC Annex II, Part 1, Section B "Machinery Directive".

# ExTensor

Powerful arguments for a future-proof technology

**+ Operating buttons**

**+ Additional switch**  
(Bistable Relay)

**+ CAN bus connection**

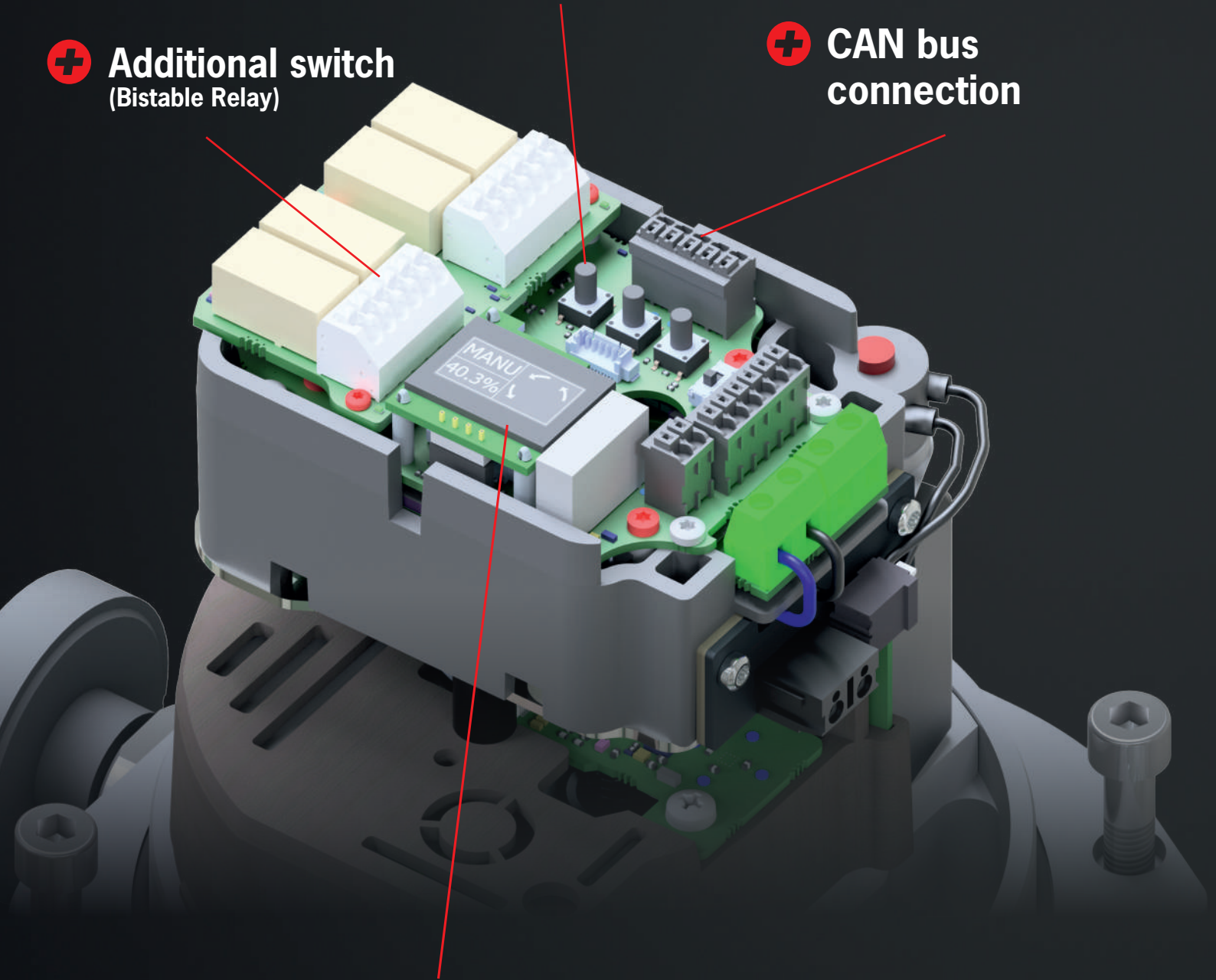

**+ OLED display**

**PLEASE NOTE**

The illustrations may include additional options.

## Highlights

- > Flexible travel from 10° to 100 revolutions
- > Position detection accurate to 0.03
- > Multi-current power supply 85 - 265 V AC or 24 V DC
- > Regulated torques and actuating times
- > Long service life (up to 259 times longer than DIN EN 15714-2:2010-02)
- > Plug and Play for options (including retrofit)
- > Blocking system and overload protection, ramps, special characteristic curves, etc.
- > Intelligent Torque Control System i-TC with torque shut-off and confirmation
- > CAN bus module (option)

### Accurate and durable

Precision gear unit with high control accuracy and increased service life.

- > High reliability

### Backlash- and wear-free

Non-contact, high-resolution and absolute position detection.

- > Consistently high precision

### Flexible and simple

Easy to configure via buttons and menu navigation.

- > Fast start-up

### High contact protection

All electrical components are 100 % covered.

- > High degree of safety

### Menu structure

- > Optimised menu guidance
- > Simplified navigation
- > Plain text display
- > Faster start-up

### Multi-line OLED display

**Functionality can be expanded based on requirements (positioner I-ACT, current output, potentiometer, CAN bus) using software validation codes**

- > no replacement of hardware required
- > Immediate availability – no lengthy delivery times
- > Functional enhancements can be quickly and easily retrofitted at any time using the software validation codes
- > Torque and actuating time can be selected
- > The performance data of the actuator can be adjusted as required by the customer
- > Different torque and actuating time combinations can be selected in the menu. The actuating times and torques can be set separately (and differently) for both directions of rotation. This makes it possible to adapt the system to the on-site requirements.

# ExTensor

## Applications, ATEX-specific



**Boiler systems**



**Industrial furnaces**



**Paint lines**



**Roasting**



**Dispensing technology**



**Industrial combustion**



**Biogas plants**



**Industrial ventilation**

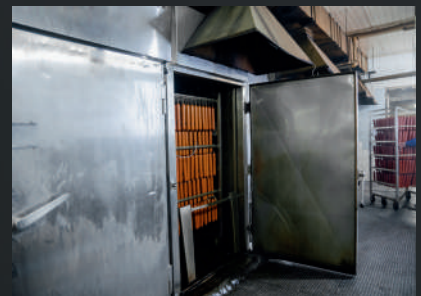

**Smokehouses**



**Environmental technology**



**Silo and bulk material technology**



**Oil and gas production / processing / storage**



**Industrial valves**



**Food technology**



**Malting technology**



**Gas control systems**



**Vehicle construction**



**Solar technology**



**Chemical plants**



**Extinguishing systems**

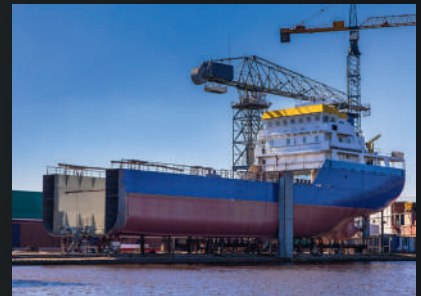

**Shipbuilding**



**Grain processing (dusts)**



**Wood processing (dusts)**



**Sewage treatment plants**



**Pharmaceutical and cosmetics industry**



**Refineries**

## Technical data



- > Intelligent Torque Control System i-TC with torque cut-off and feedback
- > CAN bus module (functional enhancement)
- > Faster start-up

- > OLED display
- > Functionality can be expanded based on requirements (positioner I-ACT, current output, potentiometer, CAN bus) using software validation codes
- No replacement of hardware required

Protection rating	<b>Protection rating against ingress of water and dust, IP protection rating: IP66 and IP67</b>
Ambient temperature	<b>Atex (gas) CE (0637) Ex II 2 G Ex db IIC T6 Gb Temperatures -20 °C to +60 °C Atex (dust) CE (0637) Ex II 2 D Ex tb IIIC T80°C Db</b>
Housing	<b>Aluminium housing – lower part milled, anodised; upper part (hood / cover) gravity die-cast, powder-coated</b>
Output shaft	<b>Various output shaft shapes – also customised</b>
Hand wheel	<b>Manual operation via hand wheel (currentless, option)</b>
Position indicator	<b>Sight glass / position indicator - standard equipment</b>
Supply voltage	<b>Multi-voltage power supply 85 - 265 V AC (alternatively 24 V DC)</b>
Additional switches	<b>Up to 4 auxiliary switches (bistable relays)</b>
Potentiometer	<b>Additional mechanical potentiometer (option)</b>
Travel	<b>from 10° to 100° revolutions</b>
Duty cycle	<b>Up to 100% duty cycle (ED)</b>
Connection	<b>3 cable entries M25 x1.5</b>
Limit switching	<b>Electronic (wear-free)</b>
Maintenance	<b>Permanent lubrication (maintenance-free)</b>
Control	<b>3-point stepping (optional positioner 12 bit, bus, ...)</b>

**PLEASE NOTE:** Illustration may contain additional options.

# ExTensor

**Size S**  
(5 to 40 Nm)



ExTensor S

**Size M/L**  
(50 to 200 Nm)



ExTensor M



ExTensor L

**Size XL**  
(250 to 500 Nm)



ExTensor XL

# SIZE S

For torques from 5 to 40 Nm



## SIZE S

Torque [Nm]	Size	Actuating time (s/90°)								
		1	3	5	10	15	30	60	80	
5	S	1	3	5	10	15	30	60	80	
10	S	1	3	5	10	15	30	60	80	
15	S	2	3	5	10	15	30	60	80	
20	S	2	3	5	10	15	30	60	80	
30	S		3	5	10	15	30	60	80	
40	S			4	10	15	30	60	80	



# DIMENSIONS

## ExTensor S

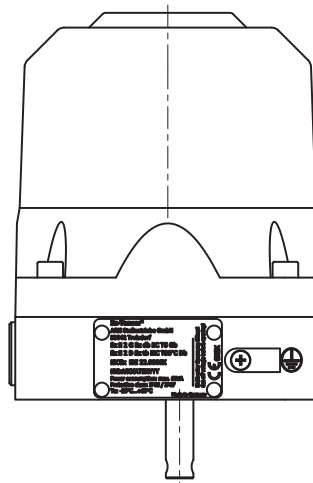
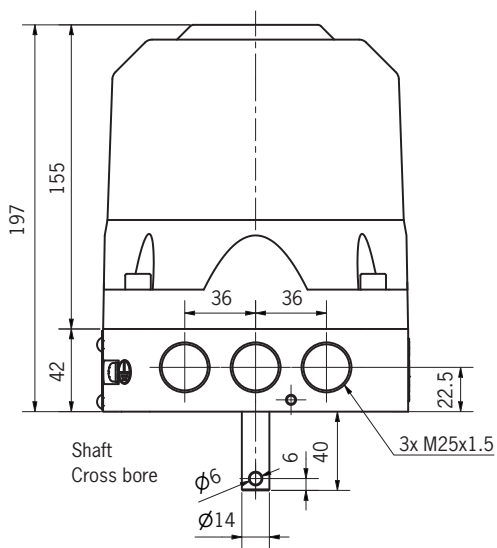
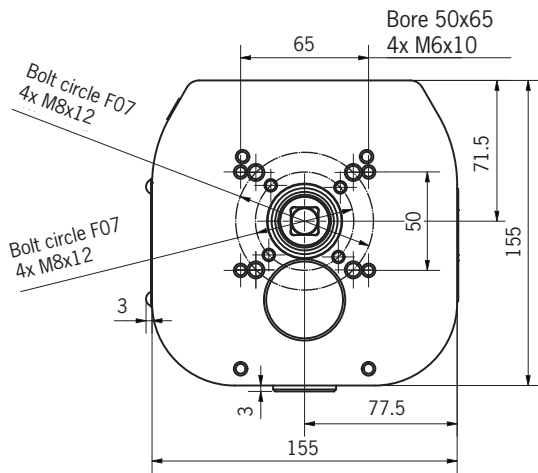

### ExTensor S

Shaft cross bore

Shaft key

Inner square shaft ISO5211

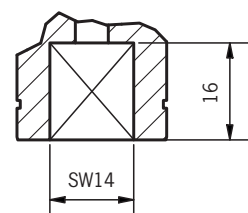
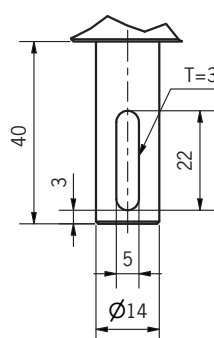
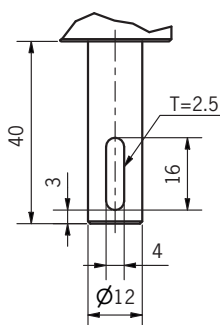
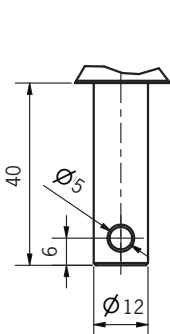

# SIZE M / L

For torques from 50 to 200 Nm



## SIZE M / L

Torque [Nm]	Size	Actuating time (s/90°)							
		5	10	15	30	60	90	120	
50	M	5	10	15	30	60	90	120	
60	M	6	10	15	30	60	90	120	
80	L	8	10	15	30	60	90	120	
100	L		10	15	30	60	90	120	
120	L		12	15	30	60	90	120	
150	L			15	30	60	90	120	
180	L			18	30	60	90	120	
200	L			20	30	60	90	120	



# DIMENSIONS

## ExTensor M

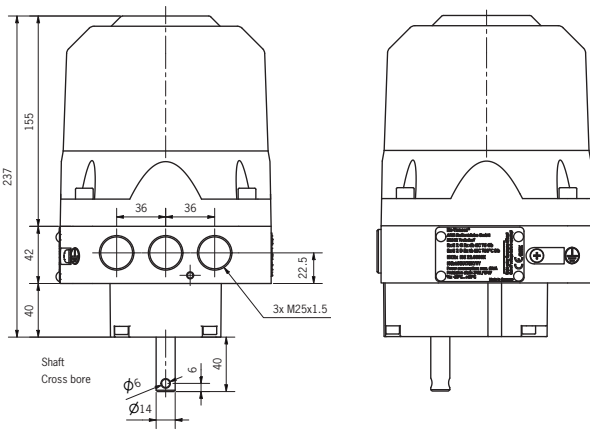
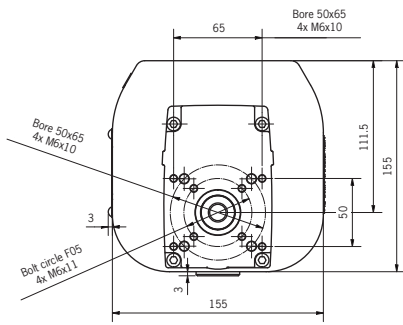

## ExTensor L

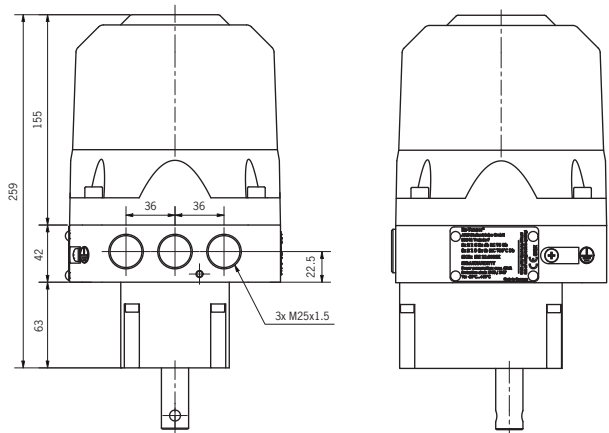
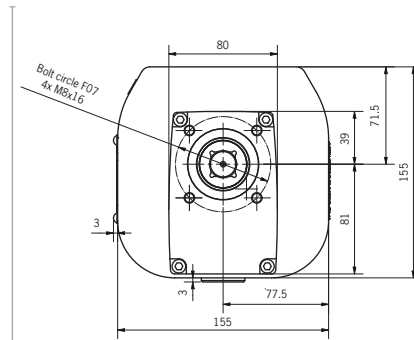

### ExTensor M

Shaft feather key

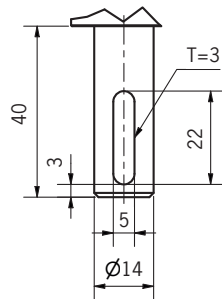

Inner square shaft ISO5211

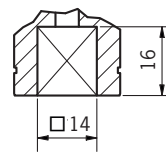

### ExTensor L

Shaft feather key

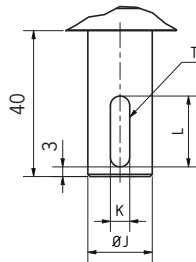

Shaft cross bore

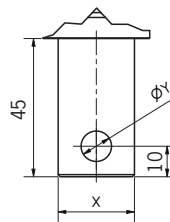

Inner square shaft ISO5211

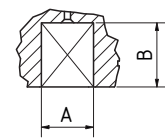

Shaft feather key				
Torque	Dimension $\varnothing J$	Dimension K	Dimension L	Dimension T
80-150	20	6 P9	22	3,5
150-180	25	8 P9	32	4

Shafts cross bore		
Torque	Dimension $\varnothing X$	Dimension $\varnothing Y$
80-150	20	8
150-180	25	10

ISO square shaft dimensions		
Torque	Dimension A	Dimension B
80-150	17	21
150-180	22	24

# SIZE XL

For torques from 250 to 500 Nm



SIZE XL

Torque [Nm]	Size	Actuating time (s/90°)					
		25	30	60	90	120	150
250	XL		30	60	90	120	150
300	XL		30	60	90	120	150
400	XL		40	60	90	120	150
500	XL		50	60	90	120	150



# DIMENSIONS

## ExTensor XL

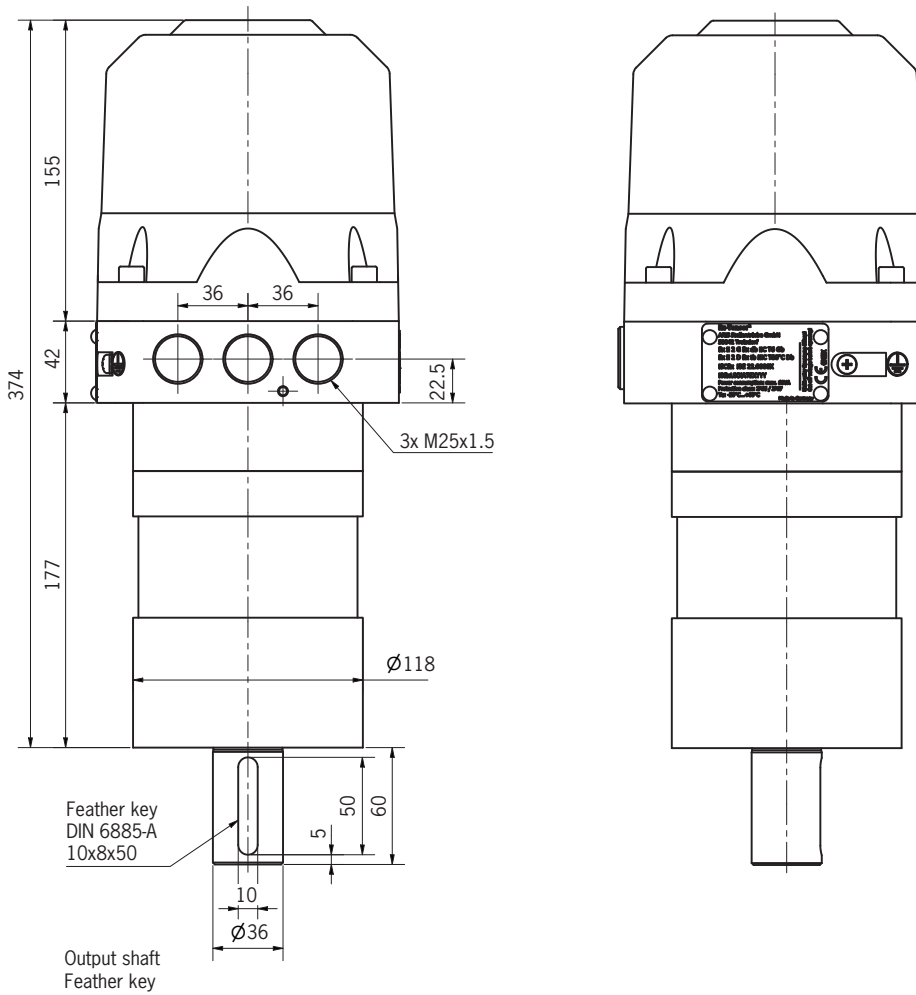
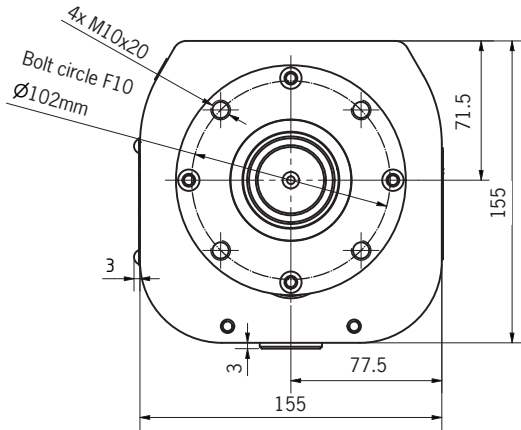

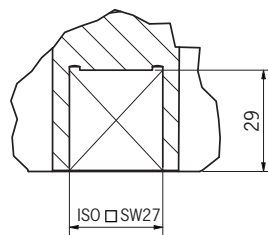

Output shaft inner square ISO5211

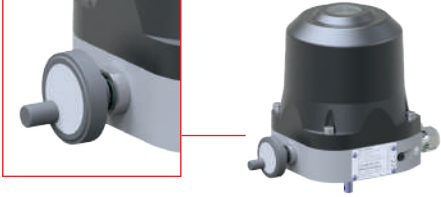

# ExTensor

## Options (mechanical)

Additional option	ExTensor	
<p>Hand wheel (option)</p>	<ul style="list-style-type: none"> <li>&gt; Lateral in the lower part</li> <li>&gt; Non-rotating</li> <li>&gt; Automatic disengagement</li> </ul>	
<p>Cable glands and blind plugs Ex-approved in accordance with ATEX and IECEx and suitable for ARIS ExTensor Zone 1 / Zone 21</p>	 <ul style="list-style-type: none"> <li>&gt; Thread M25x1.5</li> <li>&gt; Cable diameter &amp; clamping range</li> </ul> <p><b>The required cable diameter must be taken into account. Incorrect sizing will invalidate the Ex approval of the actuator.</b></p>	 <p>For closing unused cable entries. Approved in accordance with ATEX and IECEx and suitable for ARIS ExTensor Zone 1 / Zone 21 thread M25x1.5. Supplied unassembled (enclosed loose).</p>

# ExTensor

## Options / functional enhancements (electronic)

The new ARIS ExTensor software allows flexible use of the electronic functional enhancements, which can be freely selected by the customer depending on the order type.

In the highest configuration level I-ACT, the control modes “current output”, “potentiometer” and “3-point step” are always enabled and can be selected via the menu.

### Positioner I-ACT

- > Integrated in internal system bus
- > Electronic positioner
- > System resolution 12 bit
- > Setpoint inputs:
  - 0(2) to 10 V DC
  - 0(4) to 20 mA
  - Potentiometer 10 kOhm
- > Actual value output:
  - 0(2) to 10 V DC
  - 0(4) to 20 mA
- > Fault message output as switching contact
- > Special functions can be set:
  - Open-circuit detection; hysteresis; blocking protection incl. control modes “current output”, “potentiometer” and “3-point step”

### Current output

- > Integrated in internal system bus
- > Position feedback
- > System resolution 12 bit
- > Actual value output:
  - 0(2) to 10 V DC
  - 0(4) to 20 mA
- > Fault message output as switching contact

### Potentiometer (electrical)

- > Integrated in internal system bus
- > Electronic potentiometer (voltage divider)
- > Impedance 1 kOhm
- > Auto adjustment
- > Fault message output as switching contact
- > Electronic position indicator

### Potentiometer (mechanical)

- > Additional mechanical potentiometer
- > High-quality conductive plastic/wire potentiometer version

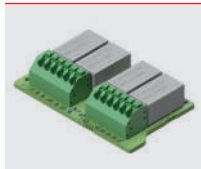

### Additional switch

- > Add-on board
- > Integrated in internal system bus
- > Additional auxiliary limit switches with freely programmable switch-on and switch-off points
- > Bistable switching state even when currentless
- > 2-way or 4-way version

### CAN bus

- > Control via CAN bus
- > Different baud rates selectable
- > Position feedback CAN bus, Alternative analogue outputs

# ExTensor

## Equipment group/equipment category: Gas

ExTensor	Gas	II 2G Ex db IIC T6 Gb
Equipment group	II	II: Equipment intended for use in places where explosive gas atmospheres are likely to occur, excluding mines susceptible to firedamp.
Equipment category	2G	2G: covers occasionally occurring & probably not, and if so, then only rarely/ briefly occurring explosive media (gases, mists, vapours)
Ignition protection rating	Ex db	Ex db: pressurised encapsulation (zone 1 & 2)
Explosion group	IIC	IIC: highest explosion protection group for gases; covers all gases, mists & vapours (including hydrogen, acetylene, carbon disulphide).
Temperature class	T6	T6: highest temperature protection class; covers the explosion protection of gases, mists, vapours that do not ignite at a maximum permissible surface temperature of the equipment of < 85 °C (e.g. hydrogen, acetylene, carbon disulphide).
Equipment Protection Level (EPL)	Gb	Gb: Description see equipment category 2G

Information in accordance with ATEX 2014/34/EU

# ExTensor

## Equipment group / equipment category: Dust

ExTensor	Dust	II 2D Ex tb IIIC T80 °C Db
Equipment group	II	II: Equipment intended for use in places where explosive dust atmospheres are likely to occur, excluding mines susceptible to firedamp.
Equipment category	2D	2D: does not cover occasionally occurring & probably by whirled up dust, and if so, then only rarely/briefly occurring explosive media (dusts)
Ignition protection rating	Ex tb	Ex tb: protection by enclosure (zone 21 & 22)
Explosion group	IIIC	IIIC: highest explosion protection group for dusts; covers all types of dusts (combustible lint, non-conductive dust & conductive dust).
Temperature class	T80°C	T80 °C: high temperature protection class; covers the explosion protection of dusts which are not ignited at a maximum permissible surface temperature of the equipment of < 80 °C.
Equipment protection level (EPL)	Db	Db: Description see equipment category 2D

Information in accordance with ATEX 2014/34/EU

# ExTensor

## Variants

### Linearis

- > Stainless steel spindle Ø 18 mm
- > Spindle pitch 40 mm/rev
- > High feed speeds, low noise and vibration
- > Holding torque thanks to the self-holding of the actuator (energised state)
- > Actuator head can be replaced separately
- > High-strength, anodised aluminium milled parts, corrosion-resistant
- > Oblong holes for fastening, ensuring quick and easy installation
- > Maintenance-free thanks to dry running, no lubrication required, no dirt adhesion to grease (increased service life)
- > Embedded (dry) lubricants in the spindle nut
- > High-quality “dryspin® technology“, spindle and nut from igus®

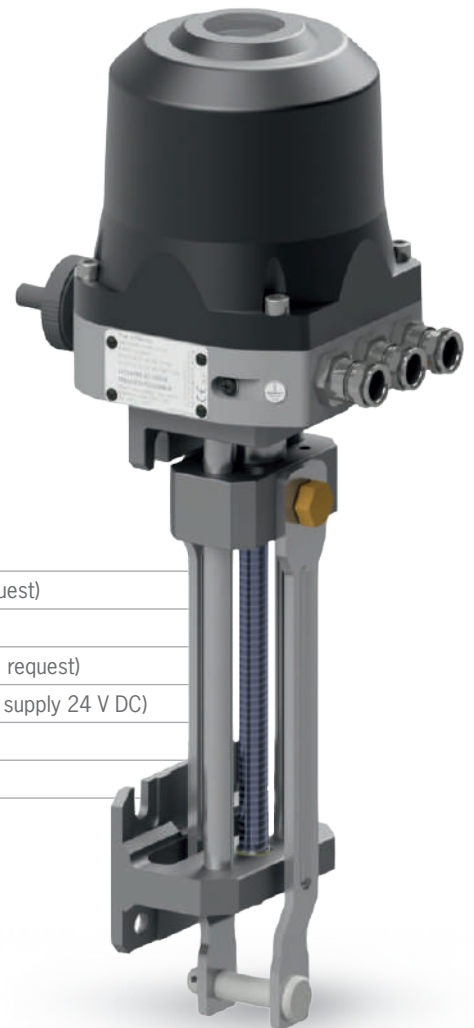

### PROPERTIES

#### LINEARIS

<b>Actuating force</b>	max. 5000 N (higher actuating forces on request)
<b>Actuating time</b>	up to 10 mm/s (load-independent)
<b>Adjustable travel</b>	150/300 mm stroke (other stroke lengths on request)
<b>Voltage</b>	85-265 V AC (alternatively low voltage power supply 24 V DC)
<b>Ambient temperature</b>	-15 °C...+60 °C
<b>Duty cycle</b>	100 %

# ExTensor

## Variants

### Ventaris (valve unit)

- > Stainless steel trapezoidal thread spindle Ø 18 mm
- > Spindle pitch 4 mm/rev
  - Precise positioning
  - Low-noise & low-vibration actuator travel
- > Self-locking of the actuator thanks to trapezoidal thread spindle
- > Actuator head can be replaced separately
- > High-strength, anodised aluminium milled parts in combination with corrosion-resistant stainless steel components
- > Flexible mounting options (direct mounting, flange mounting)
- > Maintenance-free thanks to dry running, no lubrication required, no dirt adhesion to grease (increased service life)
- > Embedded (dry) lubricants in the spindle nut
- > High-quality “dryspin® technology“, spindle and nut from igus®

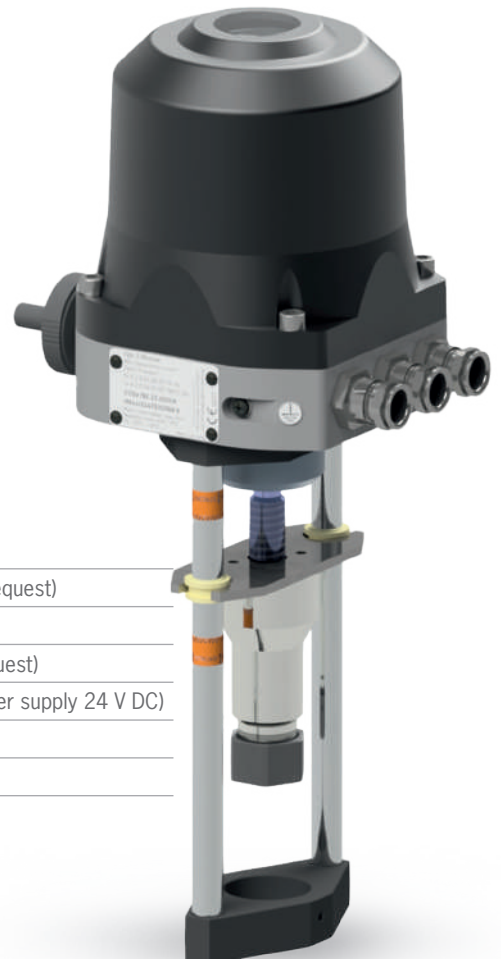

### PROPERTIES

#### VENTARIS

<b>Actuating force</b>	max. 6000 N (higher actuating forces on request)
<b>Actuating time</b>	up to 1 mm/s
<b>Travel</b>	50 mm stroke (other stroke lengths on request)
<b>Voltage</b>	85-265 V AC (alternatively low voltage power supply 24 V DC)
<b>Ambient temperature</b>	-15 °C...+60 °C
<b>Duty cycle</b>	100 %

# ExTensor

## Complete units

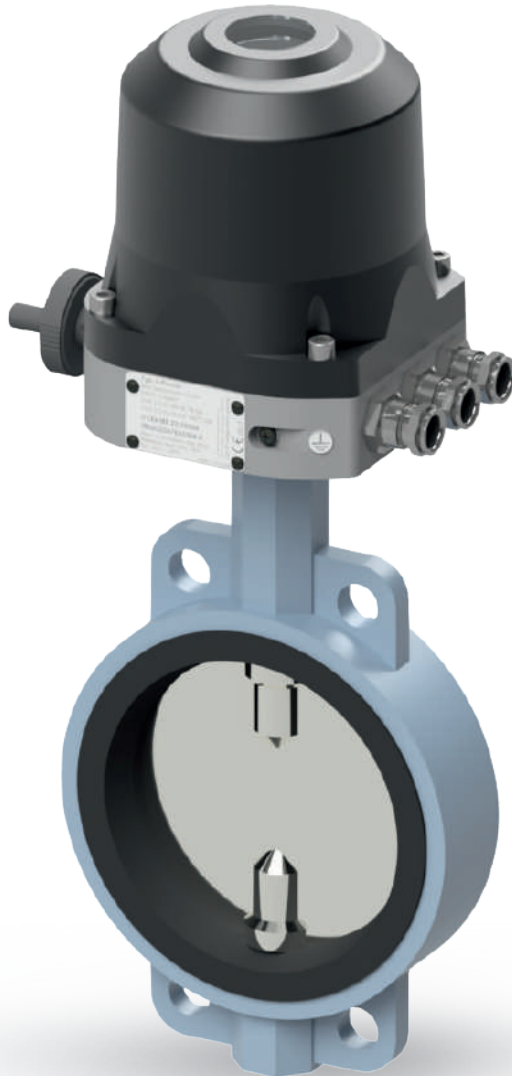

**In addition to high-quality actuators, ARIS also supplies robust industrial valves. On request, our engineers will configure a complete unit consisting of the valve, the connecting parts and the actuator to your specifications.**

The pre-assembled unit will be set to the required parameters and tested for optimal functionality. We will then ship the complete unit, securely packed together with all the relevant documentation, to your requested address ...to any location worldwide.

Choose ARIS – **Your specialist for state-of-the-art actuator and valve technology made in Germany.**





Your specialist for state-of-the-art actuator and valve technology  
for more than 40 years

ARIS Stellantriebe GmbH  
Rotter Viehtrift 9  
D-53842 Troisdorf

T. +49 2241 25186 - 0  
F. +49 2241 25186 - 99  
aris@stellantriebe.de

stellantriebe.de

Rev.  
07/2023